

Welcome to Barron Electric Cooperative's 88th Annual Meeting

*Behind Every
Meter is a
Co-op
Member!*



Rules of Order

Page 2

Rules of Order for Official Business Meeting

1. The meeting will be conducted in accordance with the current edition of Robert's Rules of Order Newly Revised and under the following special Rules of Order.
2. Members wishing to speak are to give their names and the districts in which they are members.
3. During nomination and election proceedings for directors, candidates will be allowed to speak for two minutes. One member supporting his/her candidacy will also be allowed to speak for two minutes.
4. Resolutions must have been submitted to the Resolutions Committee for consideration, as required by previous notice, and mailed to all members for action at the annual meeting. This does not preclude members from making simple motions from the floor.
5. Only members may be allowed to speak for two minutes on each issue and for one time only, except that an additional two minutes may be granted by unanimous consent.
6. No signs or handouts will be permitted within the building of the place of the meeting, except such handouts as required for the official conduct of the annual meeting. No handouts made available outside of the building will use the name of the cooperative, its letterhead or logo to imply that the cooperative supports or opposes any candidate for director or resolution.
7. No demonstrations shall be held within the building of the place of the meeting.

Official Notice

March 2024

News for You



Meet the Members Running for Districts 1, 5, and 7 at Barron Electric's 88th Annual Meeting

Members attending Barron Electric Cooperative's 88th Annual Meeting on Saturday, March 23 will be voting for members to serve on Barron Electric's Board of Directors in Districts 1, 5, and 7. Incumbent Dave Olson has submitted his nomination forms for District 1. In District 5, John Blaskowski and Incumbent Larry Kuhl both submitted their nomination forms. In District 7, Incumbent Randy Cook has submitted his nomination forms. For a full candidate profile, visit www.barronelectric.com/annual-meeting. Registration and breakfast will start at 8 a.m. at the Barron Area Community Center. The business meeting will start at 10 a.m. in the auditorium and includes reports and director elections. Jeremy Browning, Vice President of Generation at Dairyland Power Cooperative, will be the guest speaker.

More information can be found on pages 2-3 regarding Barron Electric's Annual Meeting.

District	1	2	3	4	5	6	7
Chair	Olson	Blaskowski	Kuhl	Cook			
President							
Vice President							
Secretary							
Treasurer							
Director							
Member							
Guest							

District 1



Dave Olson Spooner

District 5



John Blaskowski Rice Lake



Larry Kuhl Cumberland

District 7



Randy Cook Cameron

Official Notice

Barron Electric Cooperative's 88th Annual Meeting

Pursuant to the provision of the bylaws, notice is hereby given that the annual meeting of the members of Barron Electric Cooperative will be held Saturday, March 23, 2024 at the Barron Area Community Center in Barron with registration beginning at 8:00 a.m. The business meeting will follow at 10:00 a.m. to take action upon the following matters:

- To elect three directors to serve a three-year term in Districts 1, 5, and 7
- Presentation of reports
- To address all other business that may come before the meeting or any adjournment or adjournments, thereof.

Dated this 1st day of February 2024

Scott Warwick, Secretary

Head Table Introductions



Randy Cook
President



Jennifer Horstman
Executive Assistant/
HR Administrator



Scott Warwick
Secretary



Aaron Torud
General Manager



**Andrew
Harrington**
Cooperative
Attorney

Board of Directors Page 15



87th Annual Meeting Minutes – Pages 4, 5, 18, 19

Minutes of the 87th Annual Meeting

The 87th Annual Meeting of Barron Electric Cooperative was held on Saturday, March 25, 2023, at the Barron Senior High School in Barron, Wisconsin. Registration of members began at 8:00 a.m.

The meeting was called to order by President Randy Cook at 10:00 a.m. President Cook reported over 400 people were in attendance and asked for a moment of prayer. The National Anthem was sung by Barron High School students Jason Dau and Amelia Weise. President Cook recognized the veterans, law enforcement, first responders and health care workers. He also acknowledged and thanked the Barron VFW for serving breakfast to the members, the Barron High School Baseball and Softball teams for assisting with set up and parking and the Cameron Food Pantry. The minutes of the meeting were to be recorded by the Secretary of the Board, Scott Warwick, assisted by Executive Assistant/HR Administrator, Jennifer Horstman.

Member Michael Baker moved to adopt the Rules of Order for the Official Business Meeting, as printed on Page 2 of the Annual Report. The motion was seconded

and carried by a two-thirds show of voting cards.

Scott Warwick, Secretary of the Cooperative, read the official notice of the 87th Annual Meeting as it appeared in the cooperative's March 2023 issue of the News for You that was sent to each member during the last week of February 2023.

Persons seated at the head table were introduced by the President as follows: Aaron Torud, General Manager and Jennifer Horstman, Executive Assistant/HR Administrator. President Cook introduced the following Directors: David Olson – District I; Tim Kessler - District II; Michael Baker - District III; Scott Warwick - District IV; Larry Kuhl – District V; Patti Mandel - District VI; Randy Cook - District VII; Bill Effertz - District VIII; and Richard Bol - District IX.

The minutes of the 86th Annual Meeting were approved on March 30, 2022, at the regular scheduled meeting of the Board of Directors. The approved minutes are printed on Pages 4, 5 & 16 of the Annual Report. President Cook asked the membership for approval of assigning the Board of Directors to approve the 87th Annual Meeting minutes at their next regularly scheduled board meeting. There were no objections.

Mandy Straw, Director of Finance, presented the financial report and addressed any questions from the membership.

President Cook introduced Ron Franz, Director of Resource and Energy Planning at Dairyland Power Cooperative. Mr. Franz introduced Amanda Hoefling, Executive Vice President & Chief Administrative Officer at Dairyland Power Cooperative. Mr. Franz presented information to the members on beneficial electrification, sustainability, reliability, Dairyland's Generation Resources and the Regional Transmission Plan.

General Manager Torud presented information to the membership regarding the December 15, 2022 snow storm, cost of power, rates, SmartHub features and Barron Electric's concern for community.

In his address to the membership,



The democratic process in action at Barron Electric's 87th Annual Meeting.

President Cook reported on the state of the cooperative discussing that safety is our top priority. He also discussed the cooperative's goals on reliability and affordability.

Additional topics included Cashback Credits, the American Consumer Satisfaction Index (ACSI) score from the members, and the cooperative's plan for the future.

Activity break began at 10:52 a.m. The meeting resumed at 10:54 a.m.

Continued on pages 18 & 19



Scott Warwick
Secretary

Minutes of the 87th Annual Meeting

Director elections for Districts II, IV and VIII were scheduled for this year's meeting. The ballot tellers were presented to the membership and Dick Fankhauser was announced as the head teller. President Cook explained the qualifications to become a director and the nomination methods as described in the Bylaws of Barron Electric Cooperative.

President Cook conducted the election of directors beginning at 10:57 a.m.

District II had one candidate nominated by petition, Tim Kessler. There being no further nominations, the nominations were closed. Tim Kessler spoke on his behalf for election as director in District II.

Tim Kessler was elected Director for District II by a majority of voting cards.

District IV had one candidate nominated by petition, Scott Warwick. There being no further nominations, the nominations were closed. Scott Warwick spoke on his behalf for election as director



Pictured are the winners of the \$100 cash prizes awarded at the 87th annual meeting.



General Manager Aaron Torud talked with members at the 87th annual meeting.

in District IV. Scott Warwick was elected Director for District IV by a majority of voting cards.

District VIII had one candidate nominated by petition, Bill Effertz. There being no further nominations, the nominations were closed. Bill Effertz spoke on his behalf for election as director in District VIII.

Bill Effertz was elected director for District VIII by a majority of voting cards.

With elections complete, President Cook asked the membership for any unfinished or new business to come before the meeting. There was no unfinished or new business to come before the meeting.

General Manager Torud, President Cook and Mr. Franz addressed questions from the membership. Twelve names were drawn by Mr. Franz for \$100 cash prizes. The twelve members that received \$100 cash prizes were: Cherie Anderson, Amy Bair, Barbara Bouma, Cecilia Brierton, Busses Barron Acres, Germaine Konop, Darlene Martinson, Donald McLellan, Mary Pletzer, Donald Schleiss, Randy Wickman and Lawrence Wilhelmy.

The meeting was adjourned at 11:20 a.m.

A professional headshot of Mandy Straw, a woman with long brown hair, smiling. She is wearing a dark blazer and a necklace. The background is a light gray gradient.

Financial Report
Pages 6 – 9

Mandy Straw
Director of
Finance

Statement of Operations



	Dec. 31, 2023	
OPERATING REVENUE		\$41,375,212
OPERATING EXPENSES:		
Cost of Purchases	68,366	26,255,613
Distribution Expense - Operation		1,612,934
Distribution Expense - Other		2,792,130
Consumer Accounts		637,972
Customer Service	10,858	639,353
Administrative and General	1,862,091	2,033,319
Depreciation and Amortization Expense	3,175,951	3,331,733
Tax Expense	415,213	482,200
Interest on Long-Term Debt	1,382,880	1,666,609
Other Deductions - NET	2,481	2,500
TOTAL COST OF ELECTRIC SERVICE	39,124,106	22,154,363
OPERATING MARGINS (Revenue less Total Cost of Service)		1,920,849
NON OPERATING REVENUES:		
GENERATION SKIPPED TRUSTS		31,453
CAPITAL CREDITS	989,379	1,199,184
OTHER CAPITAL CREDITS	278,333	282,342
PATRONAGE CAPITAL	\$ 1,740,655	\$ 3,433,829

Operating Revenue
\$41,375,212

Cost of Power
\$26,255,613

Total Cost of Service
\$39,454,363

DPC Capital Credits
\$1,199,184

Patronage Capital
\$3,433,829

B
a
l
a
n
c
e
s
h
e
e
t

	Dec. 31, 2022	Dec. 31, 2023
Total Utility Plant		
\$107,875,615	\$ 101,827,272	\$ 107,875,615
		3,693
		\$ 107,879,307
Net Utility Plant		
\$65,553,350	39,604,315	42,325,957
	62,222,957	65,553,350
		21,124,702
	123,974	58,549
	20,356,824	21,183,251
Total Assets		
\$91,104,744	168,128	240,025
	1,272	901
	2,661,752	2,626,406
	256,374	30,039
	53,647	1,052,855
	271	197,718
Other Current and Accrued Assets		7,667
	3,840,879	4,155,611
	100,634	212,532
Total Margins & Equities		
\$35,457,677	86,521,294	\$ 91,104,744
		41,121,733
		5,673,609
TOTAL MARGINS AND EQUITIES		46,795,342
LIABILITIES	31,856,913	35,457,677
CURRENT LIABILITIES		
Notes Payable	3,548,482	2,888,535
Accounts Payable	3,518,236	2,507,232
Current Portion of Long-Term Debt	75,060	1,659,036
Other Current Liabilities	76	1,306,238
TOTAL CURRENT LIABILITIES		8,361,041
DEFERRED CREDITS		490,684
TOTAL LIABILITIES AND OTHER CREDITS		91,104,744



Statement of Operations

	Dec. 31, 2022	Dec. 31, 2023
OPERATING REVENUE & PATRONAGE CAPITAL.	\$ 39,549,428	\$41,375,212
OPERATING EXPENSE:		
Cost of Purchased Power	26,468,366	26,255,613
Distribution Expense - Operation	1,477,478	1,612,934
Distribution Expense - Maintenance	3,143,794	2,792,130
Consumer Accounts Expense	574,994	637,972
Customer Service and Informational Expense	620,858	639,353
Administrative and General Expense	1,862,091	2,033,319
Depreciation and Amortization Expense	3,175,951	3,331,733
Tax Expense	415,213	482,200
Interest on Long-Term Debt	1,382,880	1,666,609
Other Deductions - NET	2,481	2,500
TOTAL COST OF ELECTRIC SERVICE	39,124,106	39,454,363
OPERATING MARGINS (Revenue Less Expense)	425,322	1,920,849
NON OPERATING MARGINS - NET	47,621	31,453
GENERATION AND TRANSMISSION		
CAPITAL CREDITS	989,379	1,199,184
OTHER CAPITAL CREDITS	278,333	282,343
PATRONAGE CAPITAL OR MARGINS	\$ 1,740,655	\$ 3,433,829

B a l a n c e S h e e t

ASSETS

UTILITY PLANT

Total Utility Plant in Service
Construction Work in Progress

LESS:

Accumulated Provision for Depreciation
Net Utility Plant

OTHER PROPERTY AND INVESTMENTS

Investments in Associated Organizations
Other Investments

TOTAL

CURRENT AND ACCRUED ASSETS

Cash - General Funds
Temporary Investments
Accounts Receivable - Net Sales of Energy
Accounts Receivable - Net Other
Materials and Supplies - Electric and Other
Prepayments
Other Current and Accrued Assets

TOTAL CURRENT AND ACCRUED ASSETS

DEFERRED DEBITS

TOTAL ASSETS AND OTHER DEBITS

LIABILITIES

MARGINS AND EQUITIES

Patronage Capital
Other Margins and Equities
TOTAL MARGINS AND EQUITIES
LONG-TERM DEBT

CURRENT AND ACCRUED LIABILITIES

Notes Payable
Accounts Payable
Current Maturities Long-Term Debt
Other Current and Accrued Liabilities
TOTAL CURRENT AND ACCRUED LIABILITIES
DEFERRED CREDITS
TOTAL LIABILITIES AND OTHER CREDITS

	Dec. 31, 2022	Dec. 31, 2023
UTILITY PLANT		
Total Utility Plant in Service	\$ 101,826,747	\$ 107,875,615
Construction Work in Progress	525	3,693
	\$ 101,827,272	\$ 107,879,307
LESS:		
Accumulated Provision for Depreciation	39,604,315	42,325,957
Net Utility Plant	62,222,957	65,553,350
OTHER PROPERTY AND INVESTMENTS		
Investments in Associated Organizations	20,232,850	21,124,702
Other Investments	123,974	58,549
TOTAL	20,356,824	21,183,251
CURRENT AND ACCRUED ASSETS		
Cash - General Funds	168,128	240,025
Temporary Investments	1,272	901
Accounts Receivable - Net Sales of Energy	2,661,752	2,626,406
Accounts Receivable - Net Other	256,374	30,039
Materials and Supplies - Electric and Other	553,647	1,052,855
Prepayments	192,071	197,718
Other Current and Accrued Assets	7,635	7,667
TOTAL CURRENT AND ACCRUED ASSETS	3,840,879	4,155,611
DEFERRED DEBITS	100,634	212,532
TOTAL ASSETS AND OTHER DEBITS	\$ 86,521,294	\$ 91,104,744
LIABILITIES		
MARGINS AND EQUITIES		
Patronage Capital	42,305,887	41,121,733
Other Margins and Equities	2,163,181	5,673,609
TOTAL MARGINS AND EQUITIES	44,469,068	46,795,342
LONG-TERM DEBT	31,856,913	35,457,677
CURRENT AND ACCRUED LIABILITIES		
Notes Payable	3,548,482	2,888,535
Accounts Payable	3,518,236	2,507,232
Current Maturities Long-Term Debt	1,575,060	1,659,036
Other Current and Accrued Liabilities	1,138,976	1,306,238
TOTAL CURRENT AND ACCRUED LIABILITIES	9,780,754	8,361,041
DEFERRED CREDITS	414,559	490,684
TOTAL LIABILITIES AND OTHER CREDITS	\$ 86,521,294	\$ 91,104,744

Qualifications of a Director Per Cooperative Bylaws Article IV, Section 3

- a) Must be a member and a bona fide resident of the district and on premises served by the Cooperative at his or her primary residence, and that residence is within the director district which he or she has been nominated or elected to represent
- b) Can not be employed or financially interested in a competing business selling electric energy or engaged in selling electrical or plumbing appliances, fixtures, or supplies to the members
- c) Must not be employed by the Cooperative within the last five years
- d) Must not have been convicted of a felony or misdemeanor involving a breach of trust during the past five years preceding election or appointment as a director
- e) May not have five years preceding election or appointment as a director pursued any litigation against the Cooperative or any of its employees or directors, or who is default on any obligation owed to the Cooperative



General Manager's Report
Pages 13, 16, and 17

Aaron Torud

About Us

- Established in 1936
- 19,583 members
- 20 substations
- 2,052 square miles
- 3,210 miles of line
- 45 employees



Safety #1

- RESAP
- Safety Meetings
- Safety & Compliance Coordinator
- Random EPA visit



Members with Solar

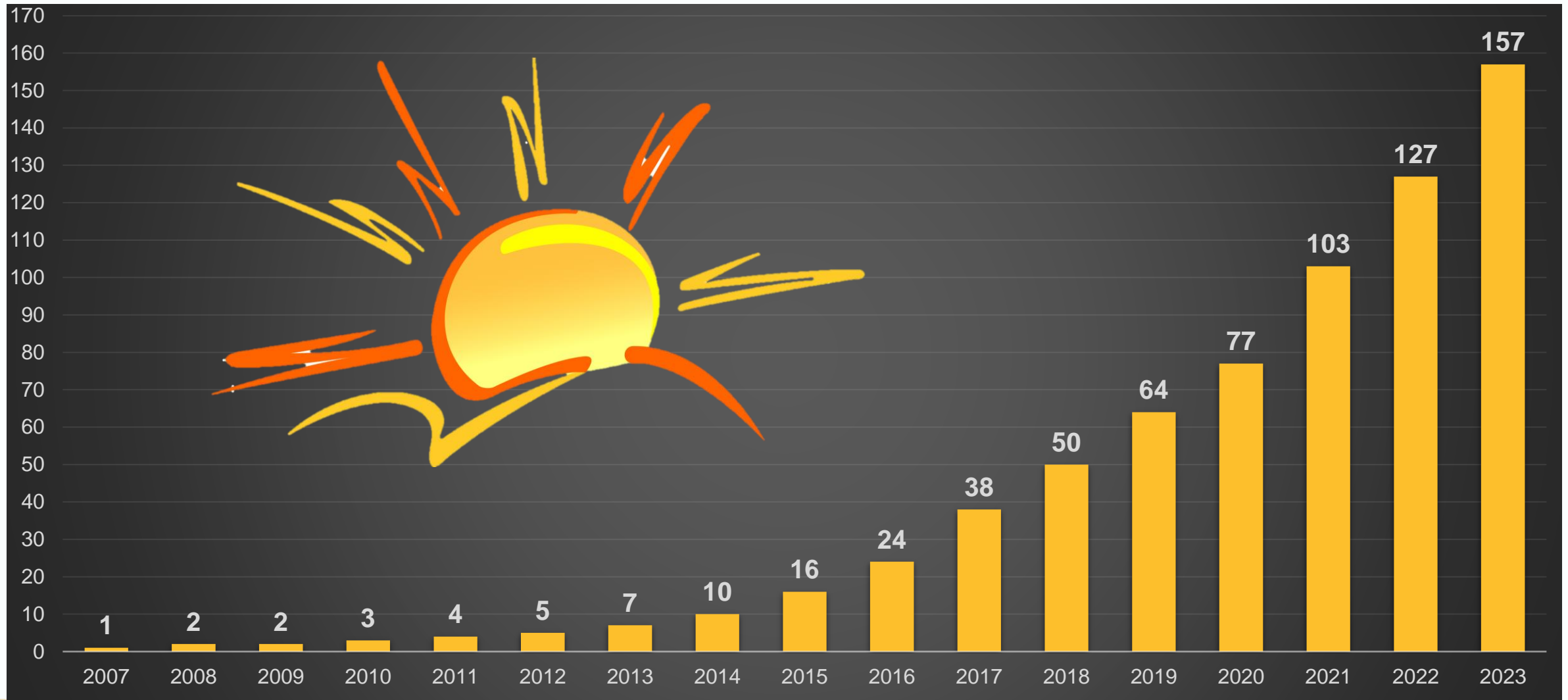

Members Beware



- SunBadger Solar
- Customers lost over \$1 Million for unfinished work in Wisconsin, Minnesota & Illinois

Potential Barron Solar

- Spooner
 - 2.25 MW
 - 15-Acre site
- Barron
 - 5 MW
 - 40-Acre site
- OneEnergy

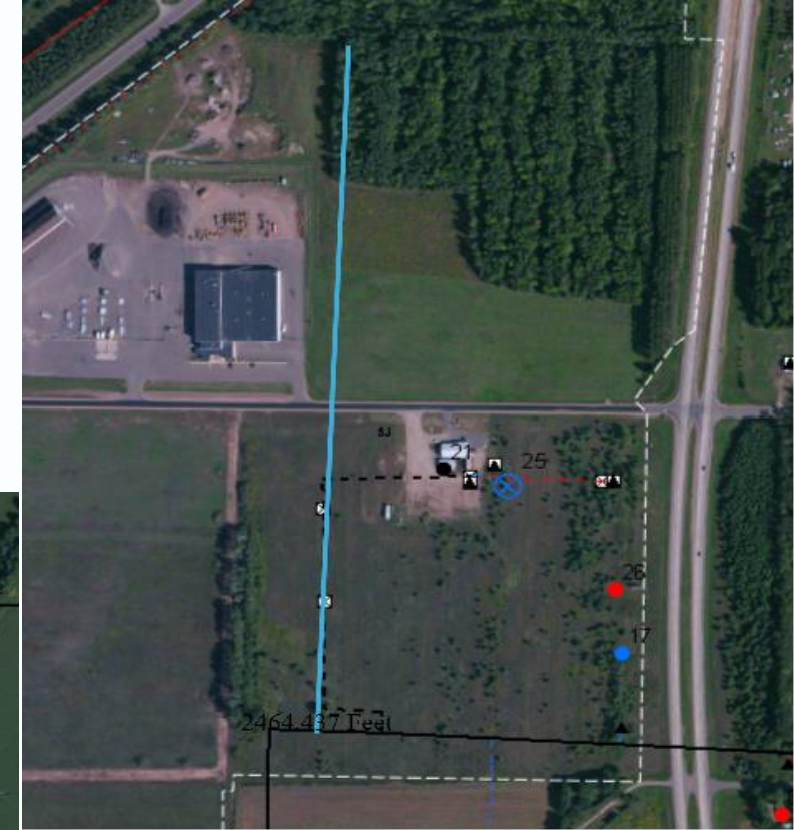
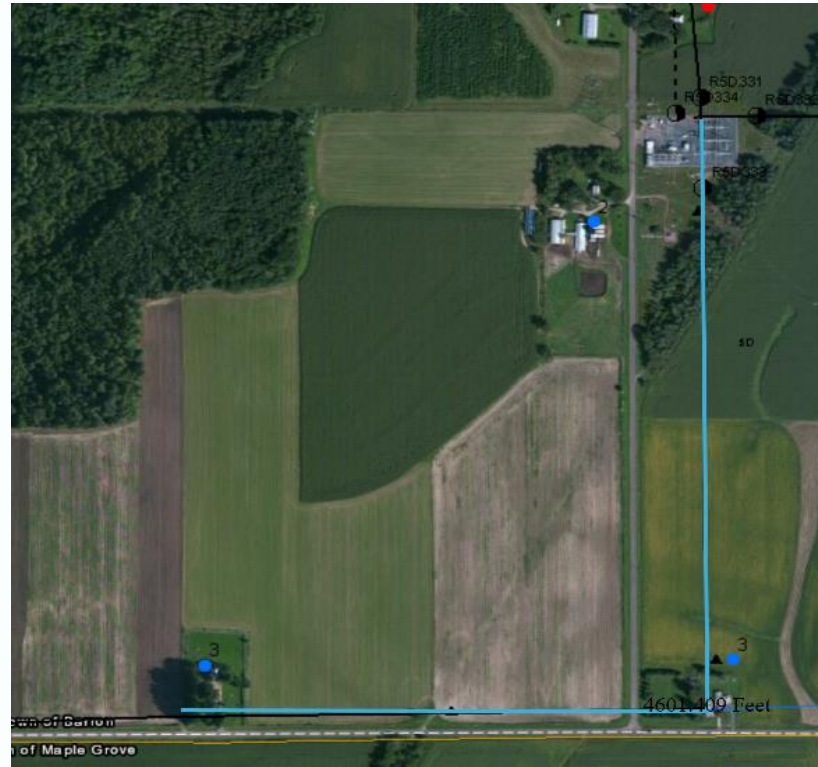

Reliability

Reliability

Reliability

What are we doing for it?



Line Replacements

- Target problem areas first (hotspots)
 - Areas with:
 - Most outages
 - Blinks
 - Cable faults
 - Inaccessible ROWs
 - We are gaining ground

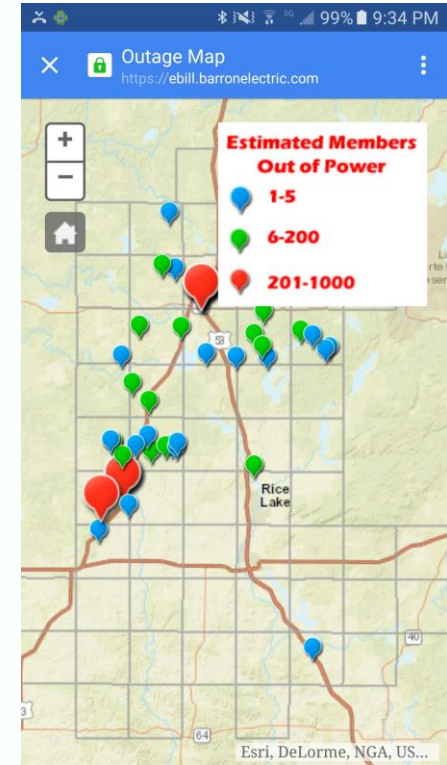

Supervisory Control and Data Acquisition - SCADA

- Control of switching in the office
 - Maintenance
 - Outages
 - Line Crew communicates
- Isolate outages to restore power faster
- Monitor substation transformers
- Long-term project

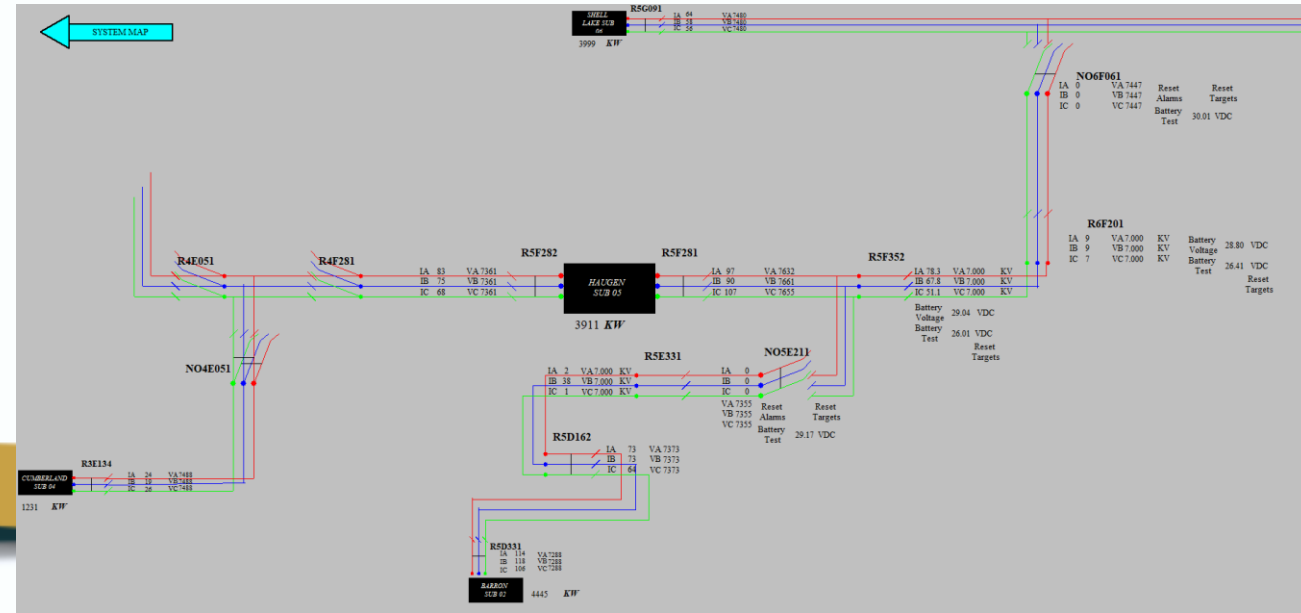

New Substations



Substation Upgrades



Right-of-Way Clearing



Reliability Continued



Technology to Enhance Reliability

- We continue moving towards proactive solutions to provide better service to our members by utilizing technology and software systems:
 - Voltage Monitoring
 - Transformer loading
 - Back feed monitoring
 - Rate options
 - Outages

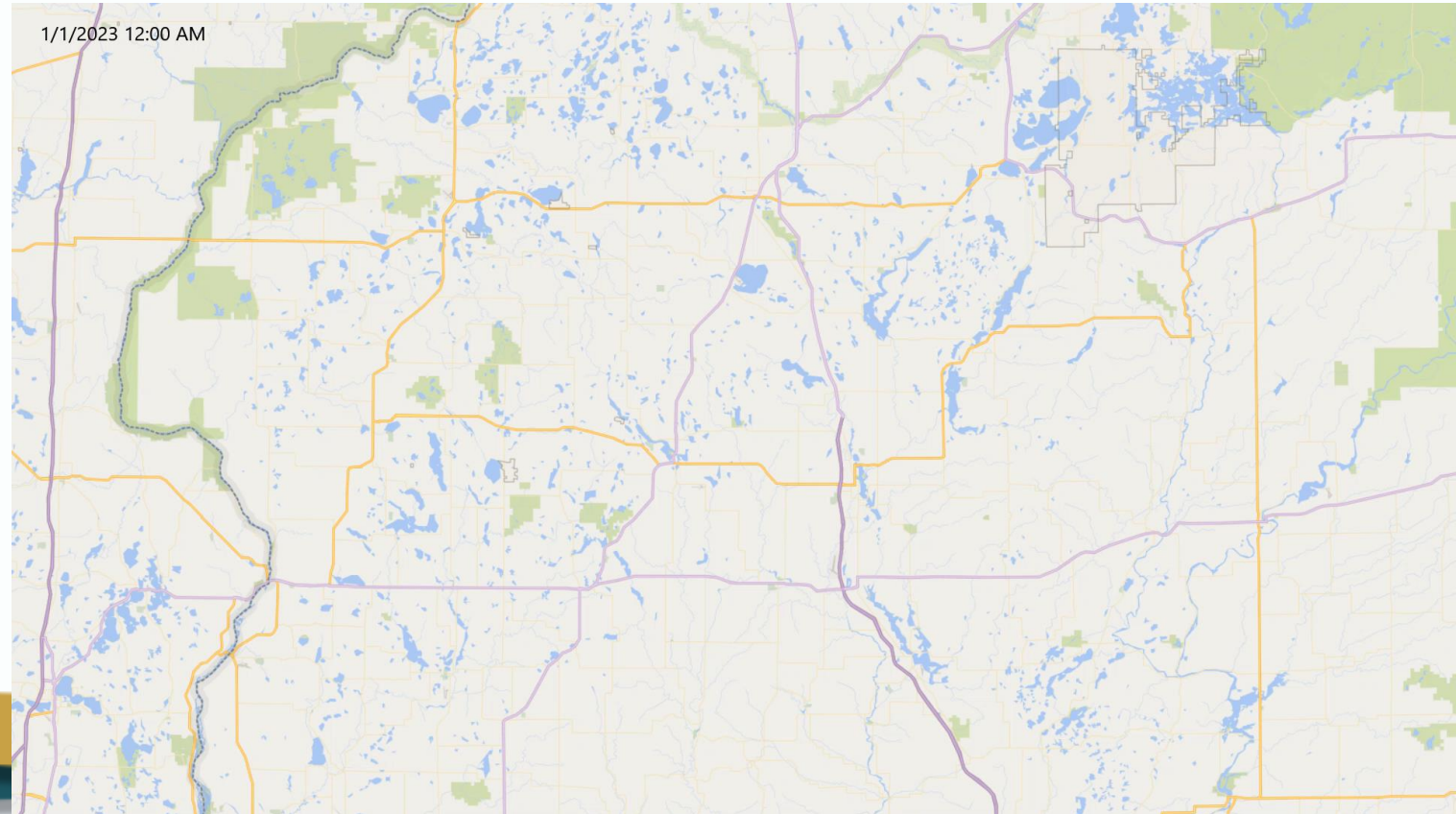



President's Report
Pages 10, 11, and 17

Randy Cook

Where Does Payment for Your Bill Go?

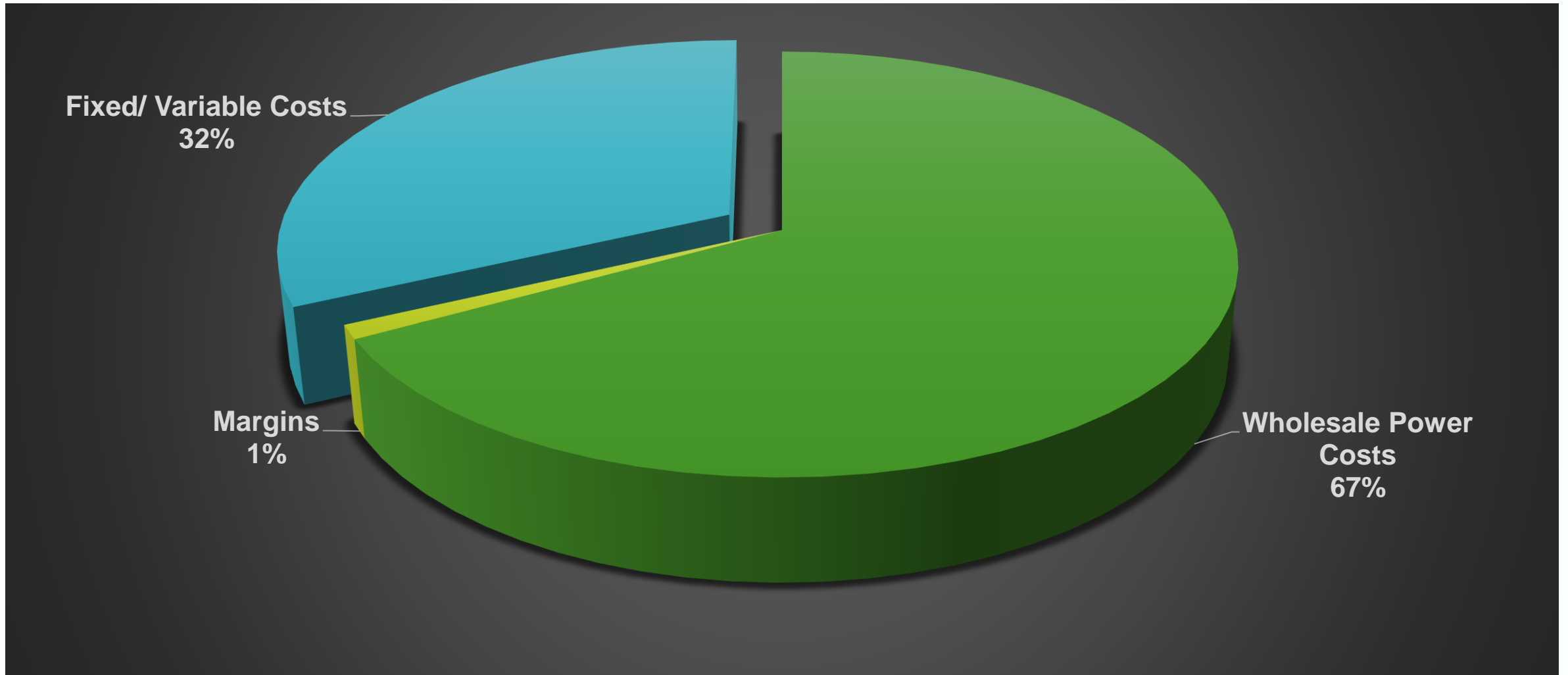

Barron Electric Rates Compared to Local Utilities

Includes facilities charge, energy charge, and taxes divided by kilowatt hours consumed

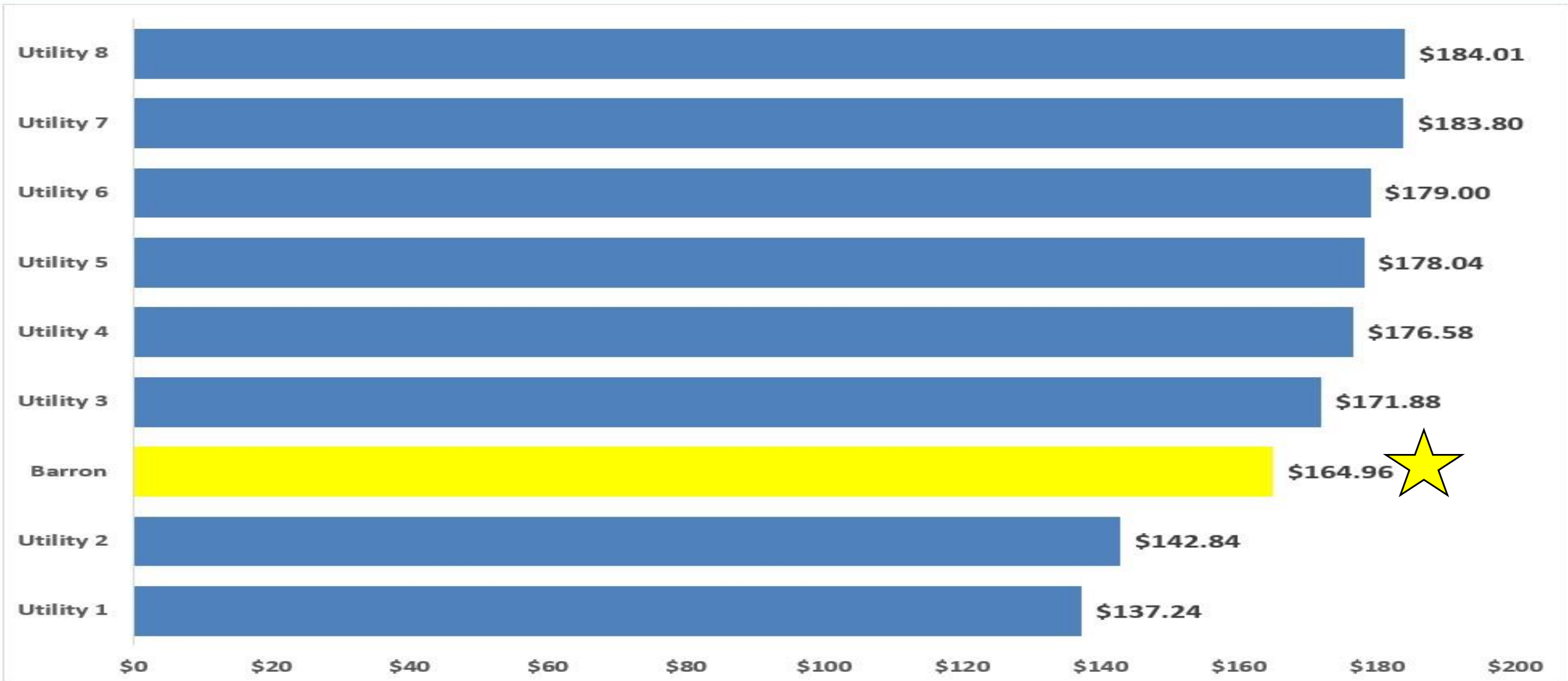

Barron Electric's New Rates

Effective January 18, 2024

Rising costs and investment in plant to deliver safe, reliable power resulted in a 4.2% rate increase

Average member using 1,200 kWh per month will see an increase of \$7.25 on their bill

Affordability



- Meeting with legislators to ensure they are working for the best interest of our members
- Investing in technology
- Offering energy-efficient programs and rebates to help members save money

Cashback Credits

- More than \$900,000 returned in 2023
- Over \$32 Million returned to members since 1965



Member Satisfaction Survey

- Over 1,000 responses
- Great feedback



How We Compare

*Data reported from the 2023
ACSI Utility Sector Report*

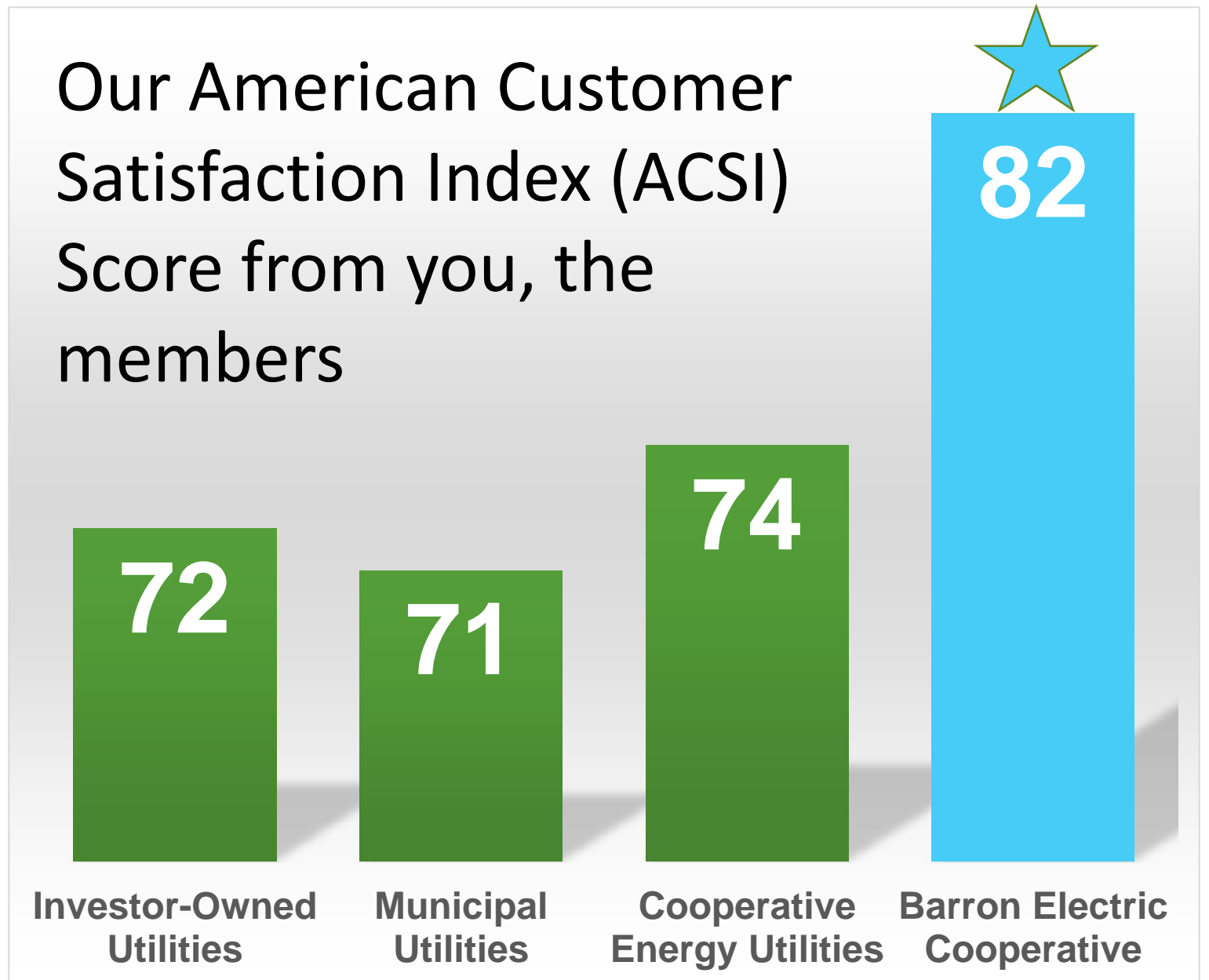

Survey Responses

- 62% of members felt their service was very reliable over the past year
- 82% of members would prefer to receive information regarding outages via texting
- 85% were in favor or neutral about carbon-free nuclear energy



Financial and
Overall Operation
of Barron Electric is
Very Strong



Board of Directors Working for You, Our Members

- Total Equity
- Distribution Equity
- Strategic Plan
- Budget Process
- Annual Independent Audit
- Director Education
- Culture of Safety

