

NEW SERVICE GUIDELINES AND DIAGRAMS

From...



Your Touchstone Energy® Cooperative 

www.barronelectric.com

email: operations@barronelectric.com

BARRON OFFICE:

P.O. Box 40
Barron, WI 54812-0040

SPOONER OFFICE:

P.O. Box 261
Spooner, WI 54801-0261

OR CALL:

(715)537-3171 Or 1-800-322-1008

Fax: (715)637-1906

OUTAGE: 1-866-258-8722

June 2021

CONTENTS

New Electric Service	1-2
The application.....	1
The right-of-way easement.....	1
The release & affidavit form.....	1
Construction fees	1-2
Meter Socket Installation	2-10
Electric code books	3
Conductor requirements.....	4
Meter socket requirements	4
Single family dwellings.....	4
Grounding specifications.....	4
Meter Pedestal.....	5
Overhead service.....	6-7
Underground service.....	8-9
Mobile home service.....	10
Off-Peak service	10

**CALL AT LEAST THREE WORK
DAYS BEFORE YOU DIG!**



811 or (800) 242-8511

For your safety, please call Diggers Hotline at least three (3) work days before beginning excavation work, so your underground wires and other facilities can be located.

Be sure to have the following information ready for the operator: your fire number and street name, closest intersection and the township and county in which your property is located.

NEW ELECTRIC SERVICE

Barron Electric Cooperative (BEC) is pleased to be your new electric service provider.

For us to begin construction of your new service, there are just a few simple steps you need to take, which are detailed in this booklet.

BEC is here to assist you in any way we can. Should you have any questions or concerns, don't hesitate to call or stop by.

The paperwork and fees

- 1) **The application.** Please complete and sign the Membership application form. Applies to new members of the cooperative only.
- 2) **The right-of-way easement.** This form must contain the *COMPLETE LEGAL DESCRIPTION* of your property (from the deed or abstract), the *PARCEL IDENTIFICATION NUMBER* (also known as the computer number), and the *NOTARIZED SIGNATURE(S)* of the appropriate landowner(s). *Please note: You may be asked to assist in getting easements for properties that BEC has to cross to serve your property. No modifications are allowed and you must use black ink to complete.*
- 3) **Release form.** Please complete appropriate information and sign.
- 4) **Affidavit.** Completed by wireman.
- 5) **Construction fees** *(must be paid in advance):*
 - Permanent:** Electric service to an improved lot (well or sewer installed, or permanent foundation), will be charged based on BEC's current rate.
 - Unimproved:** If the electric service does NOT have an existing dwelling, well or sewer, the cost to extend electric service will be charged based on BEC's current unimproved rate.

continued...

Construction fees for new service, continued:

- ❑ **Meter pole:** A meter pole is required if the dwelling does not provide an electric service connection that is a minimum of 12 feet above ground. The meter pole is purchased at the member's expense and is charged at BEC's current rate.
- ❑ **Security (Dusk til Dawn) Light:** There is a one-time installation fee per D/D light of \$50.00. Additional conduit and wire charges may also apply. The member will also be required to pay the current monthly rental rate for usage of the light.
- ❑ **Security light pole:** An additional pole is needed if you want a security light placed on a separate pole, other than on a meter pole or transformer pole. The additional pole must be purchased at the member's expense.

New Underground Meter Socket Installation (Instructions/Clarifications)

- 1) Need a 200 amp underground weatherproof (type 3R) meter enclosure. When all wires are connected and all conduits installed, the box must remain weatherproof – meaning no missing knock-out plugs or drilled holes.
- 2) The 2 inch conduit coming to and from the meter socket must be installed correctly by attaching 2-inch threaded bushings to the Schedule 80 PVC conduit before running it into meter socket and securing it on the other side (in meter) with PVC 2-inch nuts.
- 3) Any unused, removed knock-out plugs need to be permanently sealed over before socket is energized.

The information in this section addresses questions most commonly asked by our members when applying for electric service.

While this information covers *BEC's* requirements for the electrical service entrance, it is NOT meant to replace state or national codes. For a copy of either code book, please contact:

National Electric Code
National Fire Protection Association
1 Batterymarch Park
P.O. Box 9101
Quincy, MA 02269-9904
(800) 344-3555

Wisconsin State Electric Code
Department of Industry, Labor and
Human Relations
201 E Washington Avenue
Madison, WI 53702
(608) 266-3064

NOTE: If you are NOT familiar with the proper wiring procedures, we recommend contacting an electrical contractor to perform your electrical work.

Items provided by member for new electric service

- 1) Meter socket or base, bypass optional.
- 2) Disconnect if required by code.
- 3) 2" Schedule 80 PVC conduit with threaded coupling & lock ring.
- 4) Ground wire - #4 copper or equivalent.
- 5) Two 8 foot copper ground rods.

Conductor Types and Sizes

All work is to be done in accordance with the current National Electric Code (NEC) and Department of Safety and Professional Services (SPS)316

<i>Service Size</i>	<u>Copper</u> <i>Min. Size</i>	<u>Aluminum</u> <i>Min. Size</i>
100 amp.....	No. 4.....	No. 2
200 amp.....	No. 2/0	No. 4/0

Meter Socket or Base

- Meter socket or base to be furnished and installed by member or electrician on exterior wall or meter pedestal, and located so that it remains accessible to cooperative personnel.
- Meter socket must be located not less than four (4) feet nor more than six (6) feet above ground level.
- For underground installations, the meter socket type must specifically be for underground applications, and the size must be 200 amp minimum regardless of the size of the load.
- For Off-Peak service metering, please see page 10.

Grounding Specifications

- Ground wire should be #4 copper minimum or equivalent.
- Grounding conductors shall be continuous.
- Two ground rods, 8 ft. long.
- Main panel must be bonded to the neutral with bonding screw or approved bonding jumper.
- Neutral and ground bus bar shall be bonded only at central service location, not in meter socket.
- According to UDC grounding standard, either two (2) ground rods or footing grounds are acceptable.

METER PEDESTAL

Diagram A
Figure 1 - Typical Post Type Installation

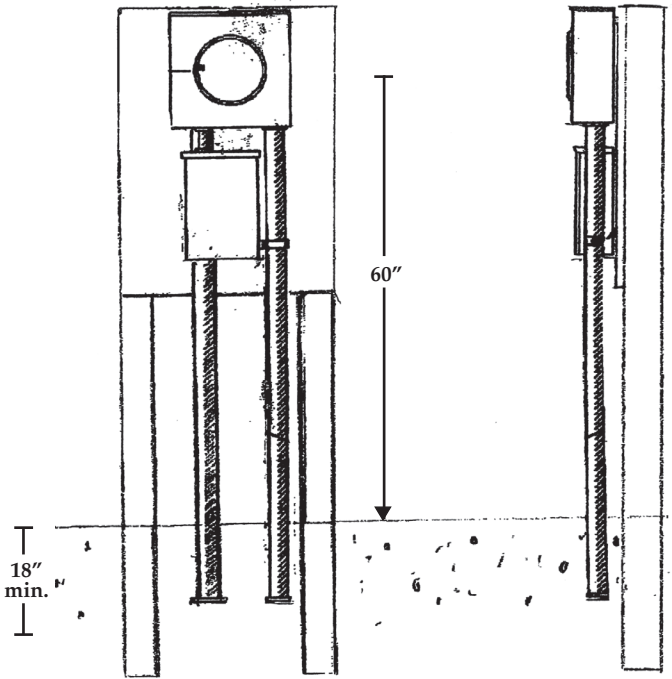
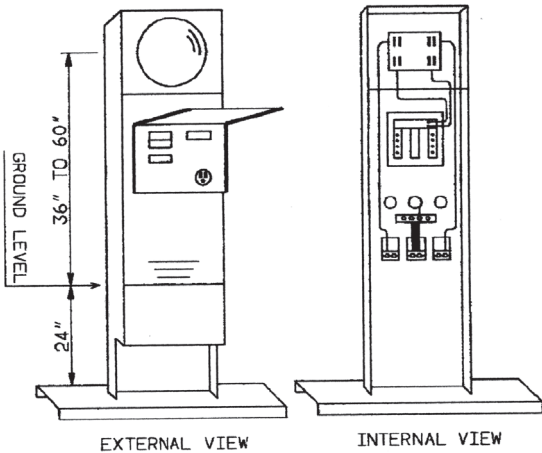

Figure 2 - Typical Stabilizing Foot Installation
Single Meter Position



OVERHEAD

Specifications for Overhead Service: Meter on Building

- 1) Overhead service with meter on building must be grounded according to **GROUNDING SPECIFICATIONS** as detailed herein.
- 2) Minimum service contact point to be 12 feet above ground for overhead service attachment.
- 3) If a "through the roof" riser (service mast) is needed to obtain the required attachment height, it shall be supported to withstand strain of service drop conductors (2-inch minimum rigid metal conduit).

Note: If service mast extends more than 36 inches above the roof line, it must be guyed.

- 4) Member's weatherhead for service entrance cables shall be located above the point of attachment of the service drop conductors to the building or other structure. *Exception: Where it is impractical to locate the service head above the point of attachment, the service head location shall be permitted not farther than 24 inches from the point of attachment.*

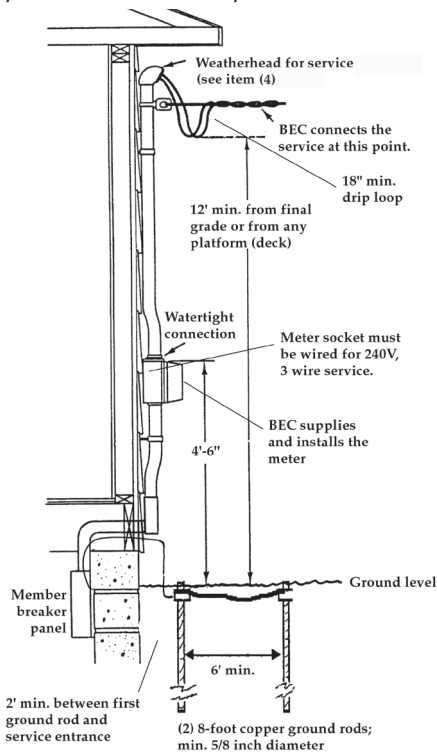

SERVICE

Specifications for Overhead Service: Meter on Pole

- 1) Pole should be in close proximity to load being served.
- 2) Member's weatherhead for service entrance cables shall be located above the point of attachment of the service drop conductors to the building or other structure. *Exception: Where it is impractical to locate the service head above the point of attachment, the service head location shall be permitted not farther than 24 inches from the point of attachment.*
- 3) Leave 18 inches minimum tail for overhead service.
- 4) Disconnecting means with overcurrent protection shall be provided to disconnect the utility wiring from the premises wiring at any point where utility wiring terminates and premises wiring continues overhead or underground.
 - (a) The service overcurrent device shall be an integral part of the service disconnecting means or shall be located immediately adjacent thereto.
 - (b) Overcurrent protection shall be provided in conjunction with all grade level switches, either as an integral part or located immediately adjacent thereto.
- 6) A separate conduit must be utilized for all load-side conductors.

UNDERGROUND

Specifications for Underground Service

Note: A minimum 200 amp underground meter socket is required on all underground services.

See diagram B

- 1) Two-inch diameter protective conduit with lockring/ bushings on each end (if PVC, bushings not needed) must be provided by the member from the bottom of the meter socket to a depth of one (1) foot below grade for service conductor. Approved Schedule 80 PVC or rigid metal conduit may be used. Thin wall conduit (EMT) is unacceptable.
- 2) All ungrounded cables and conductors extending from the central service location shall have overcurrent protection located at the central service and sized in accordance with the ampacity of the ungrounded conductor.
- 3) Disconnecting means with overcurrent protection shall be provided to disconnect the utility wiring from the premises wiring at any point where utility wiring terminates and premises wiring continues overhead or underground.
 - (a) The service overcurrent device shall be an integral part of the service disconnecting means or shall be located immediately adjacent thereto.
 - (b) Overcurrent protection shall be provided in conjunction with all grade level switches, either as an integral part or located immediately adjacent thereto.

SERVICE

Diagram B

Underground Service Installation on Home

NOTE: BEC wires the line side (top) of the meter socket.

(not to scale)

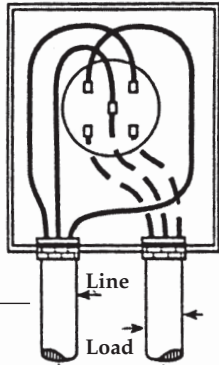

2" minimum
Schedule 80
PVC conduit

BEC's Wires
Member's wires connect at the bottom of the meter socket.

Meter socket must be wired for 240V, 3 wire service and rated for 200A underground

BEC supplies and installs the meter

4'-6"

2-foot min. between first ground rod and service entrance

(2) 8-foot copper clad ground rods; min. 5/8 inch diameter

6' min.

When a sidewalk or patio is present, conduit must extend beyond sidewalk or patio edge.

Footing ground

MOBILE/MANUFACTURED HOME

- 1.) When mobile home is served underground, a 200 amp underground meter socket must be used. See page 5 for more information on underground service.
- 2) Service to mobile homes shall comply with the NEC and the Wis. Adm. Code as they apply.
- 3) Service equipment (meter and disconnect) shall be located adjacent to the mobile home but not in or on it. Service equipment shall be located in sight from and not more than 30 feet from the mobile home it serves.

OFF-PEAK

Diagram C

Double Meter Socket Installation for Off-Peak Service

Off-peak meter sockets are available from BEC.

27-3/4"

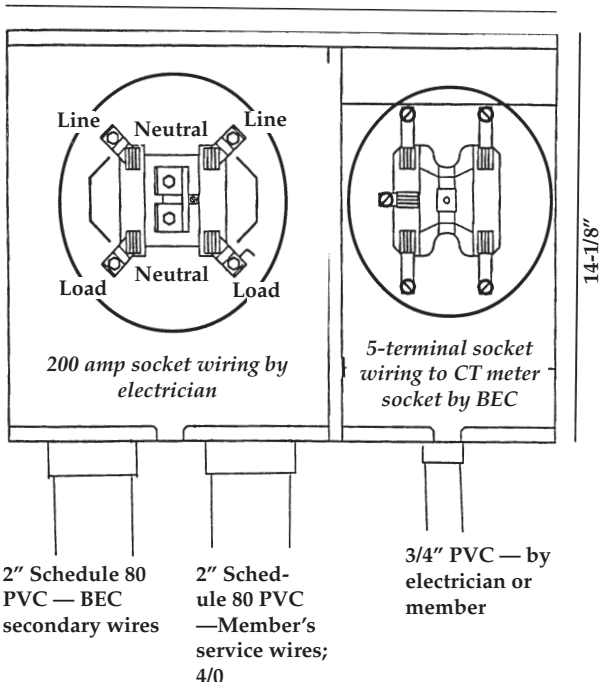

Electro Industries #E-020350E0 AARL-32940

PHONE NUMBERS FOR UDC INSPECTOR IN YOUR TOWNSHIP

Township	Contact number	Inspector	Company
Almena	715-458-0741	Daryl Dostal	Tall Pine Building Inspector
Arland	715-354-3963	Scott Schiefelbein	Independent Inspection LLC
Barron	715-458-0741	Daryl Dostal	Tall Pine Building Inspector
Barronett	715-648-5444 or 715-554-2305	Jon Mattson	Atlas Inspections
Bashaw	715-648-5444 or 715-554-2305	Jon Mattson	Atlas Inspections
Bass Lake(S)	715-634-7161 (Sawyer Co)	Steve Boss	Boss Inspection Inc.
Bass Lake(W)	715-472-8530 (Washburn Co)	Steve Boss	Boss Inspection Inc.
Bear Lake	715-458-0741	Daryl Dostal	Tall Pine Building Inspector
Beaverbrook	715-648-5444 or 715-554-2305	Jon Mattson	Atlas Inspections
Big Bend	715-314-1468	Monte Ahlers	
Birchwood	715-648-5444 or 715-554-2305	Jon Mattson	Atlas Inspections
Brooklyn	715-648-5444 or 715-554-2305	Jon Mattson	Atlas Inspections
Casey	715-648-5444 or 715-554-2305	Jon Mattson	Atlas Inspections
Cedar Lake	715-354-3963	Scott Schiefelbein	Independent Inspection LLC
Chetek	715-458-0741	Daryl Dostal	Tall Pine Building Inspector
Clayton	715-822-8537	James Price	Alder Engineering
Clear Lake	715-497-3458	Dan Kegley	REM Inspecting LLC
Clinton	715-458-0741	Daryl Dostal	Tall Pine Building Inspector
Crystal	715-648-5444 or 715-554-2305	Jon Mattson	Atlas Inspections
Crystal Lake	715-556-3136	Ben Campbell	West WI Inspections
Cumberland	715-458-0741	Daryl Dostal	Tall Pine Building Inspector
Dallas	715-790-3688	William Koelp	
Dewey	715-648-5444 or 715-554-2305	Jon Mattson	Atlas Inspections
Dovre	715-458-0741	Daryl Dostal	Tall Pine Building Inspector
Doyle	715-458-0741	Daryl Dostal	Tall Pine Building Inspector
Evergreen	715-648-5444 or 715-554-2305	Jon Mattson	Atlas Inspections
Gull Lake	715-648-5444 or 715-554-2305	Jon Mattson	Atlas Inspections
Hayward	715-634-7161	Steve Boss	Boss Inspection Inc.
Lakeland	715--354-3963	Scott Schiefelbein	Independent Inspection LLC
Long Lake	715-648-5444 or 715-554-2305	Jon Mattson	Atlas Inspections
Madge	715-648-5444 or 715-554-2305	Jon Mattson	Atlas Inspections
Maple Grove	15-790-3688	William Koelp	
Maple Plain	715-497-3458	Dan Kegley	REM Inspecting LLC
New Haven	715-235-2446 or 715-556-0066	Fred Weber	
Oak Grove	715-458-0741	Daryl Dostal	Tall Pine Building Inspector
Prairie Farm	715-235-2446 or 715-556-0066	Fred Weber	Weber Inspectors
Prairie Lake	715-354-3963 or 715-790-6963	Scott Schiefelbein	Independent Inspection LLC
Rice Lake	715-458-0741	Daryl Dostal	Tall Pine Building Inspector
Roosevelt	715-648-5444 or 715-554-2305	Jon Mattson	Atlas Inspections
Rusk (B)	715-458-0741	Daryl Dostal	Tall Pine Building Inspector
Rusk (R)	715-648-5444 or 715-554-2305	Jon Mattson	Atlas Inspections
Sampson	715-577-7983	Fred Hankel	Chippewa County Zoning
Sand Creek	715-235-2446 or 715-556-0066	Fred Weber	Weber Inspectors
Sand Lake	715-648-5444 or 715-554-2305	Jon Mattson	Atlas Inspections
Sarona	715-790-3688	William Koelp	
Scott	715-866-8148	Dennis Quinn	North Lakes Consulting
Sheridan	715-235-2446 or 715-556-0066	Fred Weber	Weber Inspectors
Sioux Creek	715-354-3963 or 715-790-6963	Scott Schiefelbein	Independent Inspection LLC
Spooner	715-648-5444 or 715-554-2305	Jon Mattson	Atlas Inspections
Springbrook	715-648-5444 or 715-554-2305	Jon Mattson	Atlas Inspections
Stanfold	715-354-3963 or 715-790-6963	Scott Schiefelbein	Independent Inspection LLC
Stanley	715-458-0741	Daryl Dostal	Tall Pine Building Inspector
Stinnett	715-634-7161	Steve Boss	Boss Inspection Inc.
Stone Lake	715-648-5444 or 715-554-2305	Jon Mattson	Atlas Inspections
Strickland	715-790-3688	William Koelp	
Stubbs	715-339-6288 or 715-820-0415	Troy Kadlecsek	T.A.K Inspectors
Sumner	715-458-0741	Daryl Dostal	Tall Pine Building Inspector
Trego	715-822-8537	James Price	Alder Engineering
Turtle Lake	715-497-3458	Dan Kegley	REM Inspecting LLC
Vance Creek	715-235-2446 or 715-556-0066	Fred Weber	State of WI